

# Plastics piping systems for soil and waste discharge (low and high temperature) within the building structure — Polypropylene (PP) —

**Part 1: Specifications for pipes, fittings  
and the system**

The European Standard EN 1451-1:1998 has the status of a  
British Standard

ICS 23.040.01; 83.140.30; 91.140.80

**NO COPYING WITHOUT BSI PERMISSION EXCEPT AS PERMITTED BY COPYRIGHT LAW**



## National foreword

This British Standard is the official English language version of EN 1451-1:1998. It supersedes BS 5254:1976 and, because the size range in EN 1451-1 also covers sizes used for waste pipes and fittings, it is one of a group of EN standards which each partially supersedes BS 5255:1989. Both BS 5254:1976 and BS 5255:1989 will be declared obsolescent with effect from 30 June 2001.

**NOTE** When first available, the ratified text of EN 1451-1:1998 gave a date of withdrawal for conflicting national standards of "June 1999", but this was subsequently changed by resolution CEN/CS 006/1999 to 2001-06-30. In the UK this date is being applied to coordinate the change-over to European Standards for plastics piping systems for this application and any consequent revision, declaration of obsolescence or withdrawal of the corresponding British Standards which are being superseded.

Products conforming to BS EN 1451-1 will be compatible with those of the same size in accordance with BS 5254:1976. The nominal sizes DN/OD 34, 41 and 54 correspond exactly with the 1¼, 1½ and 2 sizes respectively in BS 5254:1976.

Since EN 1451-1:1998 does not cover all the piping components covered by or used in conjunction with products conforming to BS 5254 and/or BS 5255, see BS 4514:1983 and its planned revision for the UK requirements for the minimum opening dimensions of access fittings, design of swept fittings, for connectors to WC pans and stand-off dimensions of pipe and fitting clips.

The UK participation in its preparation was entrusted by Technical Committee PRI/61, Plastics piping systems and components, to Subcommittee PRI/61/1, Thermoplastics piping systems and components for non-pressure applications, which has the responsibility to:

- aid enquirers to understand the text;
- present to the responsible European committee any enquiries on the interpretation, or proposals for change, and keep the UK interests informed;
- monitor related international and European developments and promulgate them in the UK.

A list of organizations represented on this subcommittee can be obtained on request to its secretary.

This British Standard, having been prepared under the direction of the Sector Committee for Materials and Chemicals, was published under the authority of the Standards Committee and comes into effect on 15 February 2000

© BSI 02-2000

ISBN 0 580 35938 7

### Amendments issued since publication

Amd. No.	Date	Comments

The responsible UK committee gives the following advice concerning the selection of alternative test conditions provided in this standard.

- a) Table 13, as referred to in 8.1, appears to present two alternative test conditions, i.e. method A or method B of EN 743:1994, without identifying where they apply or which is the reference method in case of dispute. Since these alternative test conditions might lead to conflicting results, users of this standard should declare or agree on a contractual basis which condition is to be the reference condition in case of dispute.
- b) In Table 17, reference is made to a specific point of detail in the current edition of EN 921, i.e. "types a or b" end caps, and therefore:
  - 1) the reference should be construed as relating to the current (1995) edition, as though the reference in Table 17 and hence also in clause 2 were dated accordingly;
  - 2) since alternative test conditions are permitted which may lead to conflicting results, depending on the choice of end caps, users of this standard should declare or agree on a contractual basis which condition is to be the reference condition in case of dispute.

The responsible UK committee gives the following advice concerning the specification of piping components used with piping systems conforming to this British Standard but not detailed in EN 1451-1:1998.

- c) See BS 4514:1983 and its planned revision for the UK requirements for the minimum opening dimensions of access fittings, design of swept fittings, connectors to WC pans and stand-off dimensions of pipe and fitting clips.
- d) No advice is given in EN 1451-1:1998 in respect of threaded components. The responsible UK committee (PRI/61/1) recommends that the current requirements in BS 5255:1989 are retained, i.e. if the PP fitting is intended to adapt to a threaded metal component then the thread form should conform to either BS 21 or ISO 228-1-G.
- e) Although general advice is given for the specification of swept bends and branch connections by suggesting that they follow ISO 265-1 (see 6.5), when used in England and Wales all such products must conform to the requirements of The Building Regulations 1991A (amended 1992) Approved Document H1, 1.14 and 1.22. To this end, more specific detail is given in BS 4514:1983 and in its planned revision.

Analogous provisions apply in Scotland and Northern Ireland.

- f) For external installation, which is commonplace and remains allowed in the UK, EN 1451-1:1998 only requires that additional requirements depending on the climate be agreed between the manufacturer and the user (in clause 14: otherwise, in line with European practice, EN 1451-1:1998 only gives specific requirements for products for discharge systems intended to be installed within buildings.) If the product is to be installed externally, it may require protection by painting or some other means.

The responsible UK committee gives the following advice concerning the selection and installation of piping systems and components conforming to this British Standard.

- g) The products should only be used in application area B, i.e. suspended from brackets above ground and installed in accordance with BS 5572 using the N socket variants as specified.

EN 1451-1:1998 provides a choice of three series of pipe wall thickness. When installing piping in accordance with BS 5572 (or equivalent) in above-ground situations, it is strongly recommended that series S 16 is specified and used.

For external installation, see item f) of this foreword. The advice of the manufacturer of products conforming to BS EN 1451-1 should be sought accordingly.

h) In respect of fire regulations (see 4.6), The Building Regulations 1991, Approved document B3, Section 10 requires that where PP pipe with an internal diameter greater than 40 mm (1½") penetrates a fire wall, floor or enclosure, the point of penetration is protected by a proprietary fire seal. This seal must be certificated by third-party testing to show that it is effective with PP pipes.

Analogous provisions apply in Scotland and Northern Ireland respectively.

i) For underground installations, see BS EN 1852-1 or equivalent product specifications for such situations and take account of current national installation practices, e.g. BS EN 1610 and BS EN 752.

Editorial note: Reference to regulations

In 4.4, the only "requirement" is that "pipes and fittings... shall conform to any relevant requirements on fire regulations". Since the authority for such requirements lies with national regulators and not with standards organizations, which do not have the power to waive regulations even should they so wish, this type of information in standards should be presented as a note, or as a statement in a foreword or introduction. As information it can refer in general or specific terms to the existence of current regulations/ legislation/ directives applicable to the products or the conditions of their use. The expression here as part of the normative text is inappropriate and should not be considered an acceptable precedent for other standards to follow.

#### Cross-references

The British Standards which implement international or European publications referred to in this document may be found in the BSI Standards Catalogue under the section entitled "International Standards Correspondence Index", or by using the "Find" facility of the BSI Standards Electronic Catalogue.

**Warning** This British Standard, which is identical with EN 1451-1:1998, does not necessarily detail all the precautions necessary to meet the requirements of the Health and Safety at Work etc. Act 1974. Attention should be paid to any appropriate safety precautions and the test methods referred to in EN 1451-1 should be operated only by trained personnel.

A British Standard does not purport to include all the necessary provisions of a contract. Users of British Standards are responsible for their correct application.

**Compliance with a British Standard does not of itself confer immunity from legal obligations.**

#### Summary of pages

This document comprises a front cover, an inside front cover, the EN title page, pages 2 to 32, an inside back cover and a back cover.

The BSI copyright notice displayed in this document indicates when the document was last issued.



EUROPEAN STANDARD

EN 1451-1

NORME EUROPÉENNE

EUROPÄISCHE NORM

December 1998

ICS 23.040.01; 91.140.80

Descriptors: Plastic tubes, polypropylene, water pipelines, water removal, sewage, definitions, generalities

English version

## Plastics piping systems for soil and waste discharge (low and high temperature) within the building structure - Polypropylene (PP) - Part 1: Specifications for pipes, fittings and the system

Systèmes de canalisations en plastique pour l'évacuation des eaux-vannes et des eaux usées (à basse et à haute température) à l'intérieur de la structure des bâtiments - Polypropylène (PP) - Partie 1: Spécifications pour tubes, raccords ainsi que pour le système

Kunststoff-Rohrleitungssysteme zum Ableiten von Abwasser (niedriger und hoher Temperatur) innerhalb der Gebäudestruktur - Polypropylen (PP) - Teil 1: Anforderungen an Rohre, Formstücke und das Rohrleitungssystem

This European Standard was approved by CEN on 1 June 1998.

CEN members are bound to comply with the CEN/CENELEC Internal Regulations which stipulate the conditions for giving this European Standard the status of a national standard without any alteration. Up-to-date lists and bibliographical references concerning such national standards may be obtained on application to the Central Secretariat or to any CEN member.

This European Standard exists in three official versions (English, French, German). A version in any other language made by translation under the responsibility of a CEN member into its own language and notified to the Central Secretariat has the same status as the official versions.

CEN members are the national standards bodies of Austria, Belgium, Czech Republic, Denmark, Finland, France, Germany, Greece, Iceland, Ireland, Italy, Luxembourg, Netherlands, Norway, Portugal, Spain, Sweden, Switzerland and United Kingdom.



EUROPEAN COMMITTEE FOR STANDARDIZATION  
COMITÉ EUROPÉEN DE NORMALISATION  
EUROPÄISCHES KOMITEE FÜR NORMUNG

Central Secretariat: rue de Stassart, 36 B-1050 Brussels

© 1999 CEN All rights of exploitation in any form and by any means reserved worldwide for CEN national Members.

Ref. No. EN 1451-1:1999 E

**Contents**

	Page
<b>Foreword</b> .....	3
<b>1 Scope</b> .....	4
<b>2 Normative references</b> .....	5
<b>3 Definitions, symbols and abbreviations</b> .....	7
3.1 Definitions.....	7
3.2 Symbols.....	8
3.3 Abbreviations.....	8
<b>4 Material</b> .....	9
4.1 PP-compound.....	9
4.2 Reprocessable and recyclable material.....	9
4.3 Melt mass-flow rate.....	9
4.4 Thermal stability.....	9
4.5 Sealing ring retaining means.....	9
4.6 Fire behaviour.....	9
<b>5 General characteristics</b> .....	10
5.1 Appearance.....	10
5.2 Colour.....	10
<b>6 Geometrical characteristics</b> .....	10
6.1 General.....	10
6.2 Dimensions of pipes.....	10
6.3 Dimensions of fittings.....	13
6.4 Dimensions of sockets and pipe ends.....	13
6.5 Types of fittings.....	17
<b>7 Mechanical characteristics of pipes</b> .....	22
7.1 General characteristics.....	22
7.2 Additional characteristics.....	23
<b>8 Physical characteristics</b> .....	24
8.1 Physical characteristics of pipes.....	24
8.2 Physical characteristics of fittings.....	25
<b>9 Performance requirements</b> .....	26
<b>10 Requirements for application area "BD"</b> .....	27
10.1 General.....	27
10.2 Material characteristics.....	27
10.3 Mechanical characteristics.....	28
<b>11 Sealing rings</b> .....	28
<b>12 Marking</b> .....	28
12.1 General.....	28
12.2 Minimum required marking of pipes.....	29
12.3 Minimum required marking of fittings.....	30
<b>13 Installation of piping systems</b> .....	30
<b>Annex A (informative) General characteristics of PP pipes and fittings</b> .....	31
A.1 General.....	31
A.2 Material characteristics.....	31
A.3 Ring stiffness.....	31
A.4 Chemical resistance.....	31
<b>Bibliography</b> .....	32

## Foreword

This European Standard has been prepared by Technical Committee CEN/TC 155, Plastics piping systems and ducting systems, the Secretariat of which is held by NNI.

This European Standard shall be given the status of a national standard, either by publication of an identical text or by endorsement, at the latest by June 1999, and conflicting national standards shall be withdrawn at the latest by June 1999.

This European Standard is one part of EN 1451 for plastics piping systems in the field of soil and waste discharge (low and high temperature) within the building structure made of polypropylene (PP), which consists of the following parts:

- Part 1: Specifications for pipes, fittings and the system
- Part 7: Guidance for the assessment of conformity.

Following a decision of CEN/TC 155 after the CEN enquiry, this Part 1 is the result of merging of the following parts of the draft standard prEN 1451:

- Part 1: General (published for CEN enquiry as prEN 1451-1);
- Part 2: Pipes (published for CEN enquiry as prEN 1451-2);
- Part 3: Fittings (published for CEN enquiry as prEN 1451-3);
- Part 5: Fitness for purpose of the system (published for CEN enquiry as prEN 1451-5).

Part 6: Recommended practice for installation (published for CEN enquiry as prEN 1451-6) is intended to be included in a merged document for the recommended practice for installation of plastics piping systems in the field of soil and waste discharge (low and high temperature) within the building structure. For this document the type of publication as European Prestandard (ENV) was approved by the CEN members.

For Part 7: Assessment of conformity (published for CEN enquiry as prEN 1451-7) the type of publication as European Prestandard (ENV) was approved by the CEN members.

This standard series is based on the results of the work undertaken in ISO/TC 138, Plastics pipes, fittings and valves for the transport of fluids, which is a Technical Committee of the International Organization for Standardization (ISO).

They are supported by separate standards on test methods to which references are made throughout the standard.

This part of EN 1451 includes the following annex:

- Annex A (informative): General characteristics of PP pipes and fittings

According to the CEN/CENELEC Internal Regulations, the national standards organizations of the following countries are bound to implement this European Standard: Austria, Belgium, Czech Republic, Denmark, Finland, France, Germany, Greece, Iceland, Ireland, Italy, Luxembourg, Netherlands, Norway, Portugal, Spain, Sweden, Switzerland and the United Kingdom.

## 1 Scope

This European Standard specifies the requirements for pipes, fittings and the system of polypropylene (PP) solid-wall piping systems in the field of soil and waste discharge (low and high temperature) inside buildings (marked with "B") and for soil and waste discharge systems for both inside buildings and buried in ground within the building structure (marked with "BD").

NOTE 1: The application area "inside buildings", according to this standard, applies to the interior area of the building only. The application area "within the building structure" conforms to the requirements for "inside buildings" according to prEN 12056-1.

It also specifies the test parameters for the test methods referred to in this standard.

This standard is applicable to PP pipes and fittings, their joints and to joints with components of other plastics and non-plastics materials intended to be used for the following purposes:

- a) soil and waste discharge pipework for the conveyance of domestic waste waters (low and high temperature);
- b) ventilation pipework associated with a);
- c) rainwater pipework within the building structure.

It applies to pipes and fittings, marked with "B", which are intended to be used inside buildings and outside buildings fixed onto the wall.

It applies to pipes and fittings, marked with "BD", which are intended to be used for both inside buildings and buried in ground within the building structure.

NOTE 2: Only components marked with "BD" are generally to be used buried in ground within the building structure; these are required to have a nominal ring stiffness of at least SN 4 and a nominal outside diameter equal to or greater than 75 mm.

NOTE 3: Pipes and fittings of the pipe series S 20 are intended to be used for application area "B" only.

This standard is applicable to PP pipes and fittings of the following types:

- plain-ended;
- with integral elastomeric ring seal socket;
- for butt fusion joints;

whereby the fittings can be manufactured by injection-moulding or be fabricated from pipes and/or mouldings.

NOTE 4: Components conforming to any of the Product Standards listed in the bibliography can be used with pipes and fittings conforming to this standard, provided they conform to the requirements for joint dimensions and to the functional requirements given in this standard.

This standard covers a range of nominal sizes, a range of pipe series and gives recommendations concerning colours.

NOTE 5: It is the responsibility of the purchaser or specifier to make the appropriate selection from these aspects, taking into account their particular requirements and any relevant national regulations and installation practices codes.

## 2 Normative references

This standard incorporates, by dated or undated reference, provisions from other publications. These normative references are cited at the appropriate places in the text and the publications are listed hereafter. For dated references, subsequent amendments to or revisions of any of these publications apply to this standard only when incorporated in it by amendment or revision. For undated references, the latest edition of the publication referred to applies.

### prEN 496

Plastics piping systems – Plastics pipes and fittings – Measurements of dimensions and visual inspection of surfaces

### EN 681-1

Elastomeric seals – Materials requirements for pipe joint seals used in water and drainage applications – Part 1: Vulcanized rubber

### prEN 681-2

Elastomeric seals – Materials requirements for pipe joint seals used in water and drainage applications – Part 2: Thermoplastic elastomers

### EN 728

Plastics piping and ducting systems - Polyolefin pipes and fittings - Determination of oxidation induction time

### EN 743:1994

Plastics piping and ducting systems – Thermoplastics pipes – Determination of the longitudinal reversion

### EN 744:1995

Plastics piping and ducting systems – Thermoplastics pipes – Test method for resistance to external blows by the round-the-clock method

### EN 763:1994

Plastics piping and ducting systems – Injection-moulded thermoplastics fittings – Test method for visually assessing effects of heating

### EN 921

Plastics piping systems – Thermoplastics pipes – Determination of resistance to internal pressure at constant temperature

### EN 1053

Plastics piping systems – Thermoplastics piping systems for non-pressure applications – Test method for watertightness

### EN 1054

Plastics piping systems – Thermoplastics piping systems for soil and waste discharge – Test method for airtightness of joints

### EN 1055:1996

Plastics piping systems – Thermoplastics piping systems for soil and waste discharge inside buildings – Test method for resistance to elevated temperature cycling

### EN 1277:1996

Plastics piping systems – Thermoplastics piping systems for buried non-pressure applications – Test methods for leaktightness of elastomeric sealing ring type joints

### EN 1411:1996

Plastics piping and ducting systems – Thermoplastics pipes – Determination of resistance to external blows by the staircase method

prEN 1451-7

Plastics piping systems for soil and waste discharge (low and high temperature) within the building structure – Polypropylene (PP) – Part 7: Assessment of conformity

prEN 1989

Thermoplastics piping and ducting systems – Joints for buried non-pressure applications – Test method for long-term sealing performance of joints with thermoplastic elastomer (TPE) seals by estimating the sealing pressure

EN ISO 9969

Thermoplastics pipes – Determination of ring stiffness (ISO 9969:1994)

ISO 265-1:1988

Pipes and fittings of plastics materials – Fittings for domestic and industrial waste pipes – Basic dimensions: Metric series – Part 1: Unplasticized poly(vinyl chloride) (PVC-U)

ISO 472:1988

Plastics – Vocabulary

ISO 1043-1:1997

Plastics – Symbols – Part 1: Basic polymers and their special characteristics

ISO 1133:1997

Plastics – Determination of the melt mass-flow rate (MFR) and the melt volume-flow rate (MVR) of thermoplastics

ISO 4065:1996

Thermoplastics pipes – Universal wall thickness table

ISO 4440-1:1994

Thermoplastics pipes and fittings – Determination of melt mass-flow rate – Part 1: Test method

ISO 4440-2:1994

Thermoplastics pipes and fittings – Determination of melt mass-flow rate – Part 2: Test conditions

### 3 Definitions, symbols and abbreviations

For the purposes of this standard, the following definitions, symbols and abbreviations apply.

#### 3.1 Definitions

The definitions given in ISO 472:1988 and ISO 1043-1:1997 and the following apply:

**3.1.1 application area code** a code used in the marking of pipes and fittings to indicate the permitted application area(s) for which they are intended as follows:

“B”: code for the application area inside buildings and outside buildings fixed onto the wall;

“D”: code for the application area under and within one metre from the building where the pipes and fittings are buried in ground.

“BD”: code for the application area for both, code “B” and code “D” application areas

NOTE: In code “BD” application areas the existence of external forces from the surroundings in addition to hot water discharge is usual.

**3.1.2 nominal size DN** a numerical designation of the size of a component, which is approximately equal to the manufacturing dimension, in millimetres

**3.1.3 nominal size DN/OD** nominal size, related to the outside diameter

**3.1.4 nominal outside diameter ( $d_n$ )** the specified outside diameter, in millimetres, assigned to a nominal size DN/OD

**3.1.5 outside diameter ( $d_a$ )**: The measured outside diameter through its cross-section at any point of a pipe or spigot end of a fitting, rounded to the next greater 0,1 mm.

**3.1.6 mean outside diameter ( $d_{om}$ )** the measured outer circumference of a pipe or spigot end of a fitting in any cross-section square to the pipe axis, divided by  $\pi$  ( $\approx 3,142$ ), rounded to the next greater 0,1 mm

**3.1.7 mean inside diameter of a socket ( $d_{im}$ )** the arithmetical mean of a number of measurements of the inside diameter of a socket in the same cross-section

**3.1.8 wall thickness ( $e$ )** the measured wall thickness at any point around the circumference of a component

**3.1.9 mean wall thickness ( $e_m$ )** the arithmetical mean of a number of measurements of the wall thickness, regularly spaced around the circumference and in the same cross-section of a component, including the measured minimum and the measured maximum values of the wall thickness in that cross-section

**3.1.10 pipe series S** a dimensionless number for pipe designation (see ISO 4065:1996).

**3.1.11 nominal ring stiffness (SN)** a numerical designation of the ring stiffness of a pipe or fitting, which is a convenient round number relative to the determined stiffness in kilonewtons per square metre ( $kN/m^2$ ), indicating the minimum ring stiffness of a pipe or fitting

**3.1.12 copolymer** a polymer derived from more than one species of monomer

**3.1.13 homopolymer** a polymer derived from one species of monomer

**3.1.14 virgin material** material in a form such as granules or powder that has not been subjected to use or processing other than that required for its manufacture and to which no reprocessible or recyclable material has been added

**3.1.15 own reprocessable material** material prepared from rejected unused pipes or fittings, including trimmings from the production of pipes or fittings, that will be reprocessed in a manufacturer's plant after having been previously processed by the same manufacturer by a process such as moulding or extrusion, and for which the complete formulation is known

**3.1.16 external reprocessable material** material comprising either one of the following forms:

- a) material from rejected unused pipes or fittings or trimmings therefrom, that will be reprocessed and that were originally processed by another manufacturer;
- b) material from the production of unused PP-products other than pipes and fittings, regardless of where they are manufactured

**3.1.17 recyclable material** material comprising either one of the following forms:

- a) material from used pipes or fittings which have been cleaned and crushed or ground;
- b) material from used PP-products other than pipes or fittings which have been cleaned and crushed or ground

### 3.2 Symbols

<i>A</i>	length of engagement
<i>B</i>	length of lead-in
<i>C</i>	depth of sealing zone
DN	nominal size
DN/OD	nominal size, outside diameter related
<i>d<sub>e</sub></i>	outside diameter
<i>d<sub>em</sub></i>	mean outside diameter
<i>d<sub>n</sub></i>	nominal outside diameter
<i>d<sub>s</sub></i>	inside diameter of a socket
<i>d<sub>sm</sub></i>	mean inside diameter of a socket
<i>e</i>	wall thickness
<i>e<sub>m</sub></i>	mean wall thickness
<i>e<sub>2</sub></i>	wall thickness of a socket
<i>e<sub>3</sub></i>	wall thickness in the groove area
<i>l</i>	effective length of a pipe
<i>l<sub>1</sub></i>	length of spigot
<i>R</i>	radius of swept fittings
<i>z</i>	z-lengths of a fitting
<i>α</i>	nominal angle of a fitting

### 3.3 Abbreviations

MFR	melt mass-flow rate
OIT	oxidation induction time
PP	polypropylene
PP-H	polypropylene homopolymer
TIR	true impact rate



## 4 Material

### 4.1 PP-compound

The compound for pipes and fittings shall be PP-base material (homopolymer or copolymer) to which are added those additives that are needed to facilitate the manufacture of components conforming to the requirements given in this standard.

In order to conform to national requirements on fire regulations other additives may be used.

Fabricated fittings or parts of fabricated fittings shall be made from pipes and/or mouldings conforming to this standard, except for the requirements for the wall thickness of fabricated fittings and/or mouldings from PP which conform to material, mechanical and physical characteristics as required in this standard.

### 4.2 Reprocessable and recyclable material

In addition to virgin material the use of own reprocessable material obtained during the production and testing of products conforming to this standard is permitted. External reprocessable or recyclable material shall not be used.

### 4.3 Melt mass-flow rate

The MFR of the base material shall be tested in accordance with ISO 1133:1997, condition M (test temperature: 230 °C, loading mass: 2,16 kg).

Pipes and fittings intended to be used for mechanical joints shall be made from materials with an MFR as follows:

$$\text{MFR (230/2,16)} \leq 3,0 \text{ g/10 min.}$$

Materials for pipes and fittings for butt fusion joints shall be designated by the following classes with regard to the MFR:

Class A:		MFR	≤	0,3 g/10 min;
Class B:	0,3 g/10 min	<	MFR	≤ 0,6 g/10 min;
Class C:	0,6 g/10 min	<	MFR	≤ 0,9 g/10 min;
Class D:	0,9 g/10 min	<	MFR	≤ 1,5 g/10 min.

Only pipes and fittings made from materials of the same or adjacent MFR-classes may be fused together.

### 4.4 Thermal stability

When tested in accordance with EN 728 using a test temperature of 200 °C, the oxidation induction time (OIT) of the material used for pipes and fittings intended for butt fusion shall not be less than 8 min.

### 4.5 Sealing ring retaining means

Sealing rings may be retained using means made from plastics other than PP, provided the joints conform to the requirements given in clause 9.

### 4.6 Fire behaviour

Pipes and fittings conforming to this standard shall conform to any relevant national requirements on fire regulations.

## 5 General characteristics

### 5.1 Appearance

When viewed without magnification the following requirements apply:

- the internal and external surfaces of pipes and fittings shall be smooth, clean and free from grooving, blistering, impurities and pores and any other surface irregularity likely to prevent their conformance to this standard;
- pipe ends shall be cleanly cut and the ends of pipes and fittings shall be square to each axis.

### 5.2 Colour

The pipes and fittings shall be uniformly coloured throughout their entire thickness. The colours of pipes and fittings should be preferably grey, black or white. Other colours may be used.

## 6 Geometrical characteristics

### 6.1 General

Dimensions shall be measured in accordance with prEN 496.

The figures are schematic sketches only, to indicate the relevant dimensions. They do not necessarily represent the manufactured components. The given dimensions shall be followed.

### 6.2 Dimensions of pipes

#### 6.2.1 Outside diameters

The mean outside diameter,  $d_{em}$ , shall conform to Table 1 or Table 2, as applicable.

**Table 1: Mean outside diameters  
(metric series)**

Nominal size DN/OD	Nominal outside diameter $d_n$	Dimensions in millimetres Mean outside diameter	
		$d_{em, min}$	$d_{em, max}$
32	32	32,0	32,3
40	40	40,0	40,3
50	50	50,0	50,3
63	63	63,0	63,3
75	75	75,0	75,4
80	80	80,0	80,4
90	90	90,0	90,4
100	100	100,0	100,4
110	110	110,0	110,4
125	125	125,0	125,4
160	160	160,0	160,5
200	200	200,0	200,6
250	250	250,0	250,8
315	315	315,0	316,0

**Table 2: Mean outside diameters**  
(series based on inch dimensions)

Nominal size DN/OD	Nominal outside diameter $d_n$	Dimensions in millimetres	
		Mean outside diameter	
		$d_{em, min}$	$d_{em, max}$
34	34	34,4	34,8
41	41	40,8	41,2
54	54	53,9	54,3

**6.2.2 Effective length**

The effective length of a pipe  $l$  shall not be less than that declared by the manufacturer and shall be measured as shown in Figure 1.

Single-socket pipe

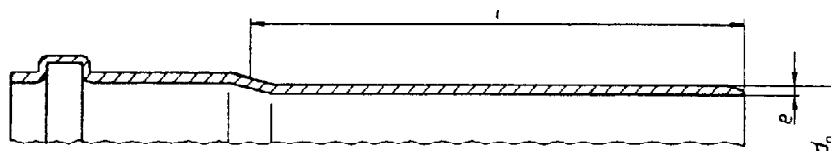

with chamfer

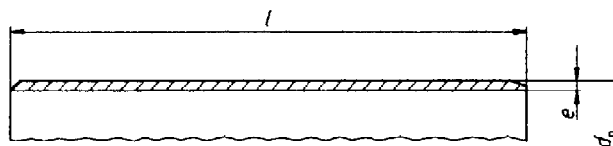

Plain-ended pipe

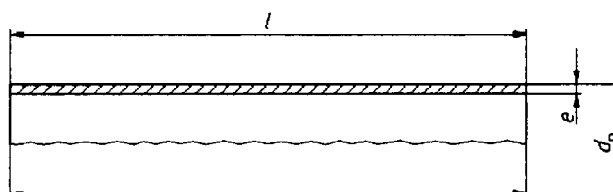

without chamfer

**Figure 1: Effective length of pipes**

**6.2.3 Chamfering**

If a chamfer is required, the angle of chamfering shall be between  $15^\circ$  and  $45^\circ$  to the axis of the pipe (see Figure 3). When pipes without chamfer are used, the pipe ends shall be deburred.

The remaining wall thickness of the end of the pipe shall be at least  $\frac{1}{2}$  of  $e_{min}$ .

**6.2.4 Wall thickness**

The wall thickness  $e$  shall conform to Table 3 or Table 4, as applicable, where for metric series a maximum wall thickness at any point up to  $1,25e_{min}$  is permitted, provided that the mean wall thickness  $e_m$  is less than or equal to the specified  $e_{m, max}$ .

**Table 3: Wall thickness**  
(metric series)

Dimensions in millimetres

Nominal size DN/OD	Nominal outside diameter $d_n$	Pipe series					
		S 20 <sup>1)</sup>		S 16		S 14	
		Wall thickness					
		$e_{min}$	$e_{m,max}$	$e_{min}$	$e_{m,max}$	$e_{min}$	$e_{m,max}$
32	32	1,8	2,2	1,8	2,2	1,8	3,0
40	40	1,8	2,2	1,8	2,2	1,8	3,0
50	50	1,8	2,2	1,8	2,2	1,8	3,0
63	63	1,8	2,2	2,0	2,4	2,2	3,1
75	75	1,9	2,3	2,3	2,8	2,6	3,1
80	80	2,0	2,4	2,5	3,0	2,8	3,3
90	90	2,2	2,7	2,8	3,3	3,1	3,7
100	100	2,5	3,0	3,2	3,8	3,5	4,1
110	110	2,7	3,2	3,4	4,0	3,8	4,4
125	125	3,1	3,7	3,9	4,5	4,3	5,0
160	160	3,9	4,5	4,9	5,6	5,5	6,3
200	200	4,9	5,6	6,2	7,1	—	—
250	250	—	—	7,7	8,7	—	—
315	315	—	—	9,7	10,9	—	—

<sup>1)</sup> For application area "B" only.

**Table 4: Wall thickness**  
(series based on inch dimensions)

Dimensions in millimetres

Nominal size DN/OD	Nominal outside diameter $d_n$	Wall thickness <sup>1)</sup>	
		$e_{min}$	$e_{m,max}$
		34	34
41	41	1,9	2,3
54	54	2,0	2,4

<sup>1)</sup> For application area "B" only.

### 6.3 Dimensions of fittings

#### 6.3.1 Outside diameters

The mean outside diameter  $d_{em}$  of the spigot end shall conform to Table 1 or Table 2, as applicable.

#### 6.3.2 z-lengths

The z-length(s) of fittings (see Figure 6 to Figure 19) shall be given by the manufacturer.

NOTE: The z-length of a fitting is intended to assist in the design of moulds and is not intended to be used for quality control purposes. ISO 265-1:1988 can be used as a guideline.

#### 6.3.3 Wall thickness

The minimum wall thickness  $e_{min}$  of the body or the spigot end of a fitting shall conform to Table 3 or Table 4, as applicable, except that a reduction of 5% resulting from core shifting is permitted. In such a case the average of two opposite wall thicknesses shall be equal to or exceed the values given in Table 3 or Table 4, as applicable.

Where a fitting or adaptor provides for a transition between two nominal sizes, the wall thickness of each connecting part shall conform to the requirements for the applicable nominal size. In such a case the wall thickness of the fitting body is permitted to change gradually from the one wall thickness to the other.

Where a sealing ring is located by means of a retaining cap or ring (see Figure 2) the wall thickness in this area shall be calculated by addition of the wall thickness of the socket and the wall thickness of the retaining cap or ring at the corresponding places in the same cross-section.

The wall thickness of fabricated fittings, except for spigot end and socket, may be changed locally by the fabrication process, provided that the minimum wall thickness of the body conforms to  $e_{3,min}$  as given in Table 7 or Table 8, as appropriate for the pipe series S concerned.

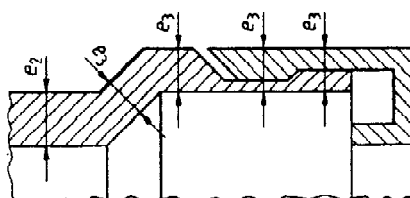

Figure 2: Example for calculation of the wall thickness of sockets with retaining cap

### 6.4 Dimensions of sockets and pipe ends

#### 6.4.1 Dimensions of ring seal sockets and spigot ends

##### 6.4.1.1 Diameters and lengths

The diameters and lengths of ring seal sockets and spigot ends (see Figure 3, Figure 4 or Figure 5) shall conform to Table 5 or Table 6, as applicable, and shall be in accordance with the following conditions:

- Where sealing rings are firmly retained, the dimensions for the minimum value for A and the maximum value for C shall be measured to the effective sealing point (see Figure 5 as an example). This point shall give a full sealing action.
- Where sealing rings are firmly retained, requirements for dimension B (see Figure 4) do not apply.

Different designs of ring seal sockets (see Figure 4) are permitted, provided the joints conform to the requirements given in clause 9.

**Table 5: Diameters and lengths of ring seal sockets and spigot ends**  
(metric series)

Dimensions in millimetres

Nominal size DN/OD	Nominal outside diameter $d_n$	Socket				Spigot end $l_{1, min}$
		$d_{sm, min}$	$A_{min}$	$B_{min}$	$C_{max}$	
32	32	32,3	24	5	18	42
40	40	40,3	26	5	18	44
50	50	50,3	28	5	18	46
63	63	63,3	31	5	18	49
75	75	75,4	33	5	18	51
80	80	80,4	34	5	19	53
90	90	90,4	34	5	20	54
100	100	100,4	35	5	21	56
110	110	110,4	36	6	22	58
125	125	125,4	38	7	26	64
160	160	160,5	41	9	32	73
200	200	200,6	45	12	40	85
250	250	250,8	68	15	50	118
315	315	316,0	81	19	63	144

**Table 6: Diameters and lengths of ring seal sockets and spigot ends**  
(series based on inch dimensions)

Dimensions in millimetres

Nominal size DN/OD	Nominal outside diameter $d_n$	Socket				Spigot end $l_{1, min}$
		$d_{sm, min}$	$A_{min}$	$B_{min}$	$C_{max}$	
34	34	34,8	25	3,8	12	37
41	41	41,2	25	3,8	15	40
54	54	54,3	25	3,8	18	43

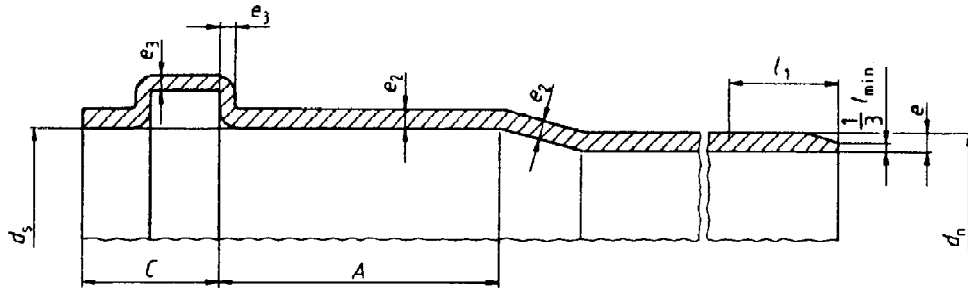

Ring seal socket without chamfer

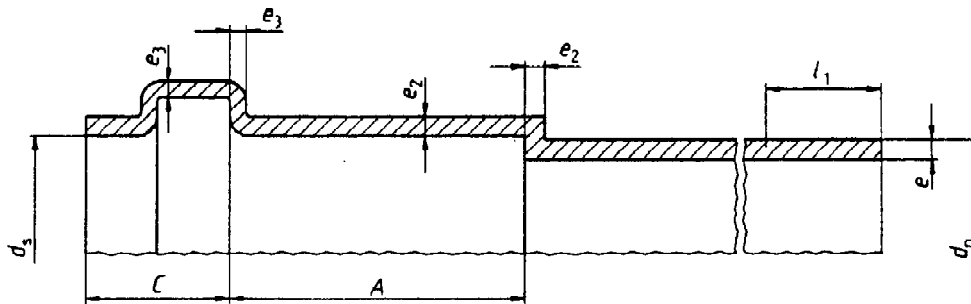

Ring seal socket with chamfer

Figure 3: Dimensions of sockets and spigot ends for ring seal joints

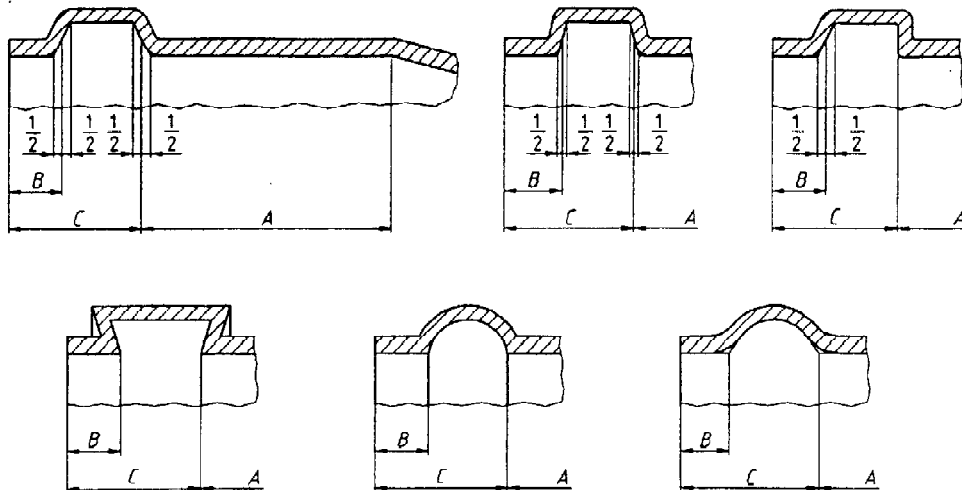

Figure 4: Typical groove designs for ring seal sockets

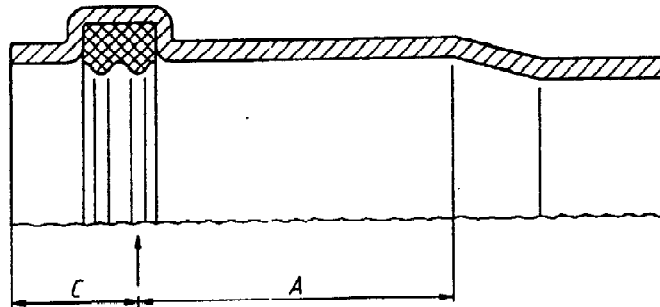

Figure 5: Effective sealing point

6.4.1.2 Wall thickness of ring seal sockets

The wall thickness of the socket  $e_2$  and the wall thickness in the groove area  $e_3$  shall conform to Table 7 or Table 8, as applicable.

Table 7: Wall thickness of sockets  
(metric series)

Dimensions in millimetres

Nominal size DN/OD	Nominal outside diameter $d_n$	Pipe series					
		S 20 <sup>1)</sup>		S 16		S 14	
		Wall thickness					
		$e_{2, \min}$	$e_{3, \min}$	$e_{2, \min}$	$e_{3, \min}$	$e_{2, \min}$	$e_{3, \min}$
32	32	1,6	1,0	1,6	1,0	1,6	1,0
40	40	1,6	1,0	1,6	1,0	1,6	1,0
50	50	1,6	1,0	1,6	1,0	1,6	1,0
63	63	1,6	1,0	1,7	1,1	2,0	1,3
75	75	1,7	1,1	2,1	1,3	2,4	1,5
80	80	1,7	1,1	2,3	1,4	2,6	1,6
90	90	2,0	1,3	2,6	2,1	2,8	2,4
100	100	2,3	1,4	2,8	2,4	3,2	2,7
110	110	2,4	1,5	3,1	2,6	3,5	2,9
125	125	2,8	1,8	3,6	3,0	3,9	3,3
160	160	3,5	2,2	4,5	3,7	5,0	4,2
200	200	4,4	2,7	5,6	4,7	—	—
250	250	—	—	7,0	5,8	—	—
315	315	—	—	8,8	7,3	—	—

<sup>1)</sup> For application area "B" only.



**Table 8: Wall thicknesses of sockets**  
(series based on inch dimensions)

Nominal size DN/OD	Nominal outside diameter $d_n$	Dimensions in millimetres	
		Wall thicknesses <sup>1)</sup>	
		$e_{2, \min}$	$e_{3, \min}$
34	34	1,7	1,0
41	41	1,8	1,1
54	54	1,8	1,1

<sup>1)</sup> For application area "B" only.

#### 6.4.2 Dimensions of pipe ends for butt fusion joints

The mean outside diameter  $d_{em}$  and the wall thickness  $e$  of pipes with plain ends intended to be used for butt fusion joints shall conform to the same pipe series S, as specified in this standard.

#### 6.5 Types of fittings

This standard is applicable for the following types of fittings. Other designs of fittings are permitted.

- a) Bends (see Figures 6, 7, 8, 9, 10 or 11)
  - unswept or swept angle (see ISO 265-1:1988);
  - spigot/socket or socket/socket;
  - butt fused from segments.

The fixed nominal angle  $\alpha$  should be as follows: 15°, 22,5°, 30°, 45°, 67,5°, 80° or 87,5° to 90°.

- b) Branches and reducing branches (branching single or multiple) (see Figures 12, 13, 14, 15, 16 or 17)
  - unswept or swept angle (see ISO 265-1:1988);
  - spigot/socket or socket/socket.

The fixed nominal angle  $\alpha$  should be as follows: 45°, 67,5° or 87,5° to 90°.

If other angles are required, they shall be agreed between the manufacturer and purchaser and be identified accordingly.

- c) Reducers (see Figure 18)
- d) Access fittings (see Figure 19)

The inside diameter of the cleaning hole shall be as specified by the manufacturer.

- e) Couplers
  - Double socket (see Figure 20);
  - Repair collar (see Figure 21).
- f) Push-fit socket for butt fusion for pipe ends (see Figure 22)
- g) Plugs (see Figure 23).

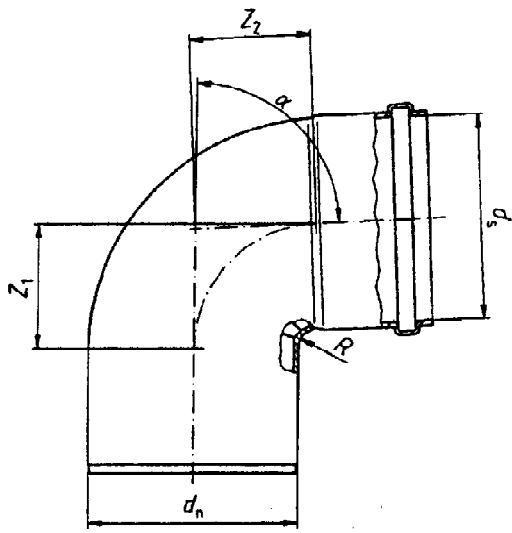

**Figure 6: Bend with single socket (unswept)**

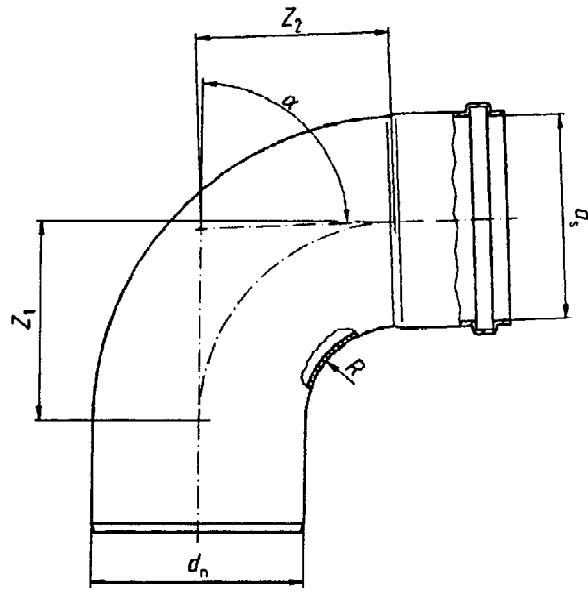

**Figure 7: Bend with single socket (swept)**

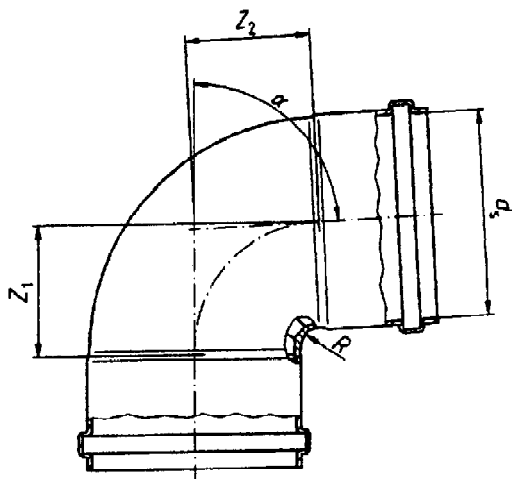

**Figure 8: Bend with all sockets (unswept)**

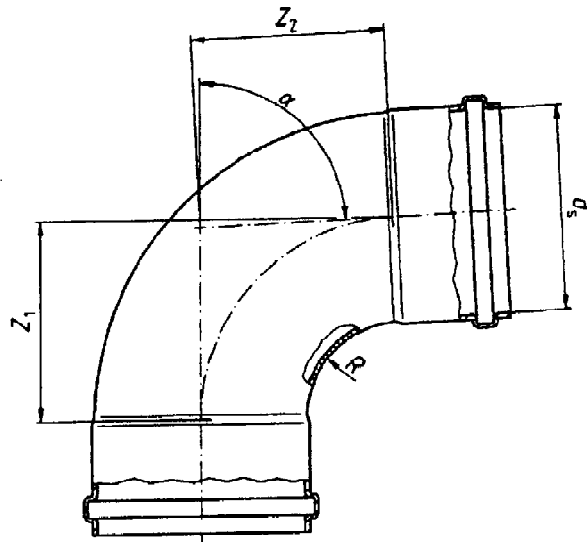

**Figure 9: Bend with all sockets (swept)**

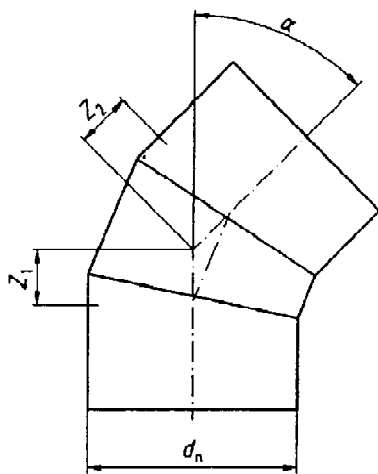

Figure 10: Bend, butt fused from segments

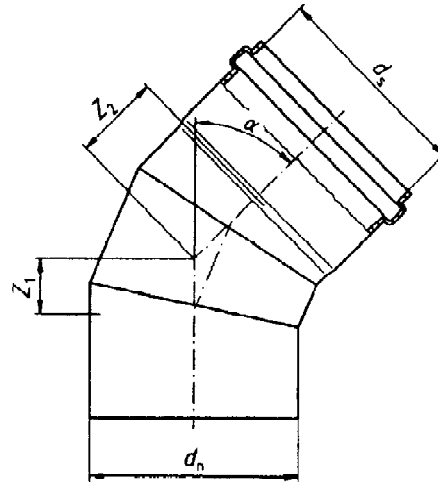

Figure 11: Bend with single socket, butt fused from segments

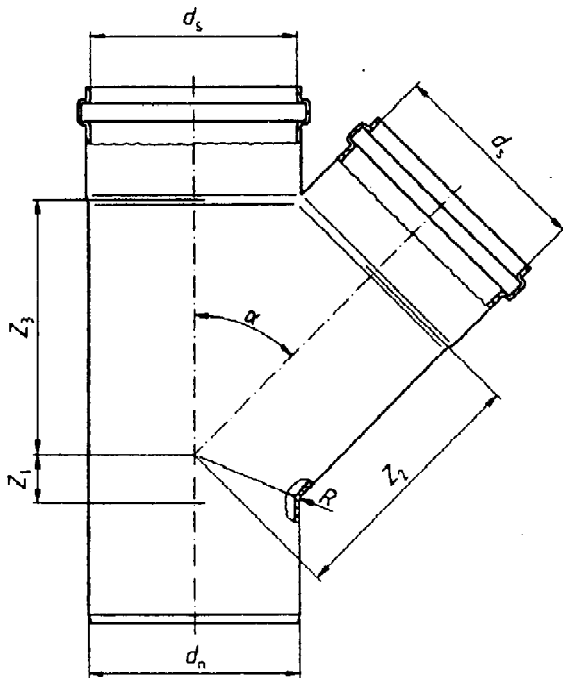

Figure 12: Branch (unswept)

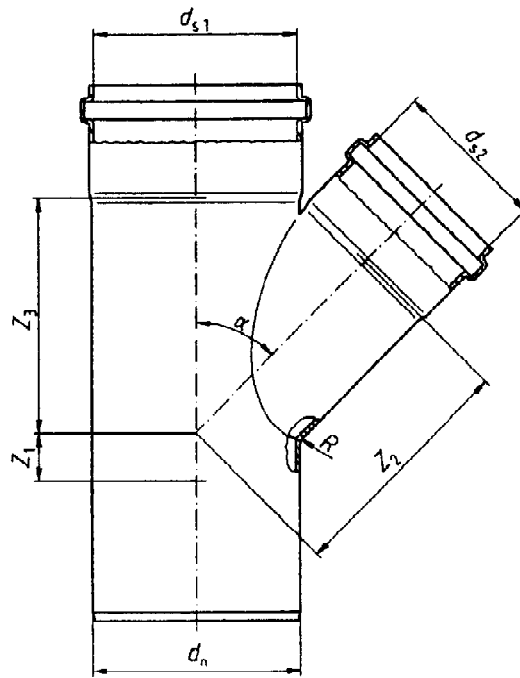

Figure 13: Reducing branch (unswept)

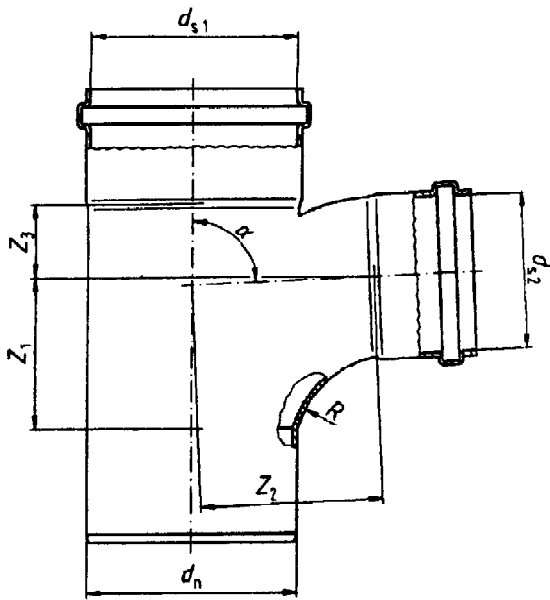

Figure 14: Reducing branch (swept)

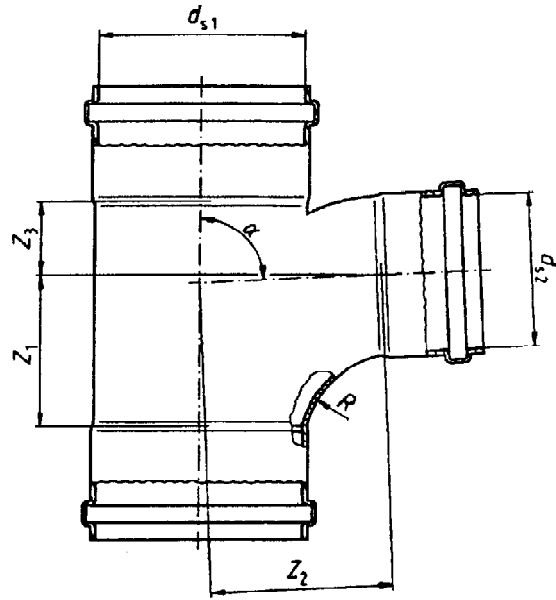

Figure 15: Reducing branch with all sockets (swept)

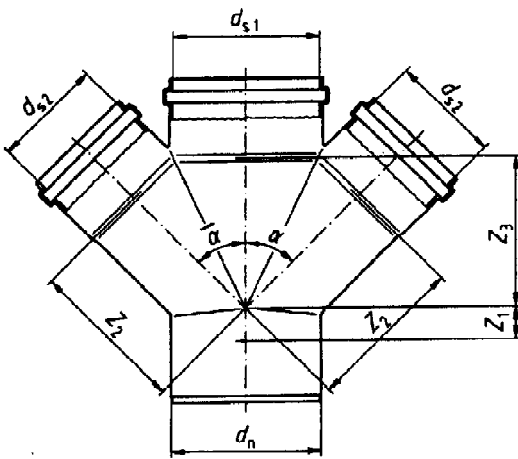

Figure 16: Double branch

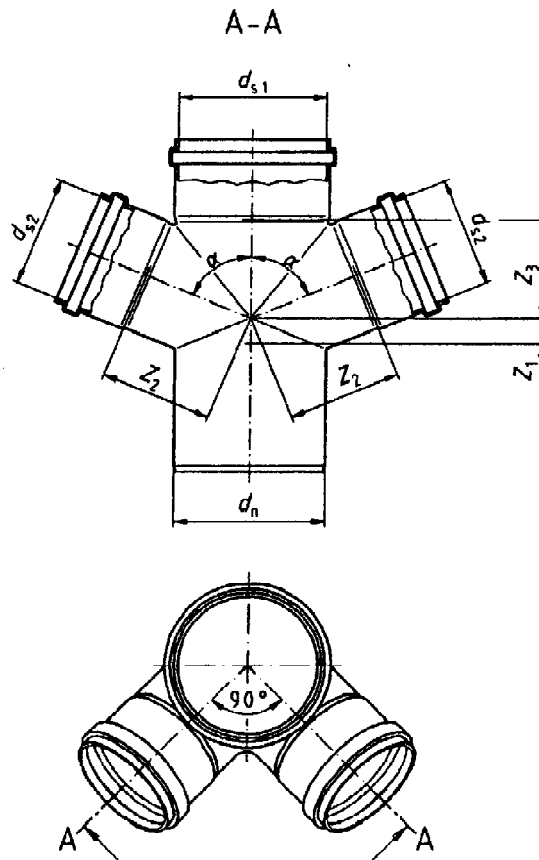

Figure 17: Angular double branch

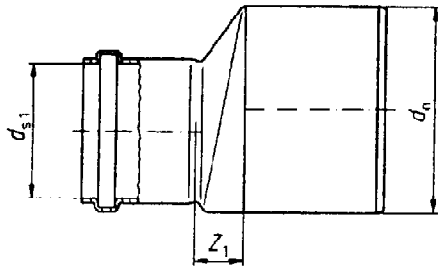

Figure 18: Reducer

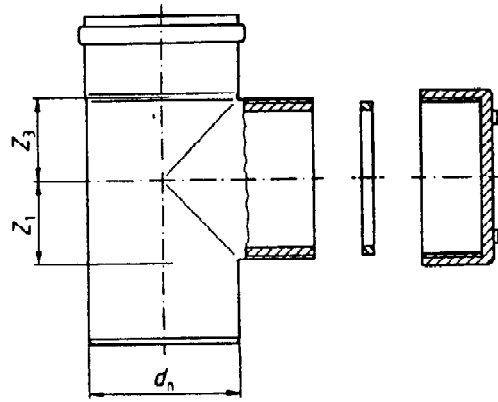

Figure 19: Access fitting with round cleaning hole

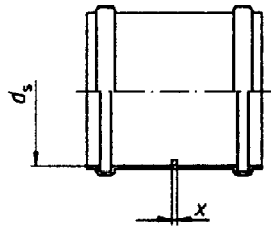

Figure 20: Double socket

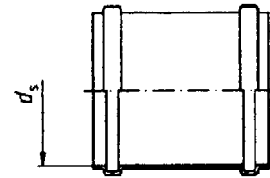

Figure 21: Repair collar

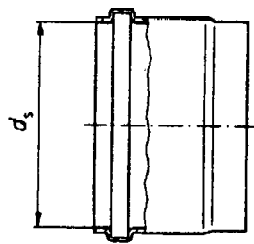

Figure 22: Push-fit socket for butt fusion of pipe ends

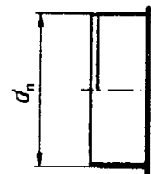

Figure 23: Plug

**7 Mechanical characteristics of pipes**

**7.1 General characteristics**

When tested in accordance with the test method as specified in Table 9 using the indicated parameters, the pipe shall have general mechanical characteristics conforming to the requirements given in Table 9.

The mass and fall height of striker for determining the impact resistance (round-the-clock method) as specified in Table 9 are given in Table 10 or Table 11, as applicable.

**Table 9: General mechanical characteristics of pipes**

Characteristic	Requirement	Test parameters		Test method
PP-copolymer: Impact resistance <sup>1)</sup> (round-the-clock method)	TIR ≤ 10 %	Mass of striker Fall height of striker  Type of striker for: $d_n < 110$ mm $d_n ≥ 110$ mm Conditioning medium Conditioning temperature Conditioning period Sampling procedure	Tables 10 or 11 Tables 10 or 11  d 25 d 90 Water or air (0 ± 1) °C 60 min prEN 1451-7	EN 744:1995
PP-H: Impact resistance (round-the-clock method)	TIR ≤ 10 %	Mass of striker Fall height of striker  Type of striker for: $d_n < 110$ mm $d_n ≥ 110$ mm Conditioning medium Conditioning temperature Conditioning period Sampling procedure	Tables 10 or 11 Tables 10 or 11  d 25 d 90 Air (23 ± 2) °C 60 min prEN 1451-7	EN 744:1995
<sup>1)</sup> In case of indirect testing (see prEN 1451-7) the preferred temperature is (23 ± 2) °C.				

**Table 10: Masses and fall heights of striker for impact resistance**  
(round-the-clock method)  
(metric series)

Dimensions in millimetres

Nominal size DN/OD	Nominal outside diameter $d_n$	Mass of striker kg + 0,01 0	Fall height of striker + 20 0
32	32	0,5	600
40	40	0,5	800
50	50	0,5	1 000
63	63	0,8	1 000
75	75	0,8	1 000
80	80	0,8	1 000
90	90	0,8	1 200
100	100	0,8	1 200
110	110	1,0	1 600
125	125	1,25	2 000
160	160	1,6	2 000
200	200	2,0	2 000
250	250	2,5	2 000
315	315	3,2	2 000

**Table 11: Masses and fall heights of striker for impact resistance**  
(round-the-clock method)  
(series based on inch dimensions)

Dimensions in millimetres

Nominal size DN/OD	Nominal outside diameter $d_n$	Mass of striker kg + 0,01 0	Fall height of striker + 20 0
34	34	0,5	600
41	41	0,5	800
54	54	0,5	1000

**7.2 Additional characteristics**

Pipes made from PP-copolymers intended to be used in areas where installation is usually carried out at temperatures below -10 °C, shall additionally conform to the requirements of an impact test (staircase method) as specified in Table 12.

The pipes shall be marked in accordance with Table 19.

**Table 12: Additional mechanical characteristics of pipes**

Characteristic	Requirements	Test parameters		Test method
Impact resistance <sup>1)</sup> (staircase method)	$H_{50} \geq 1$ m max one break below 0,5 m	Conditioning and test temperature	(0 ± 1) °C	EN 1411
		Type of striker	d 90	
		Mass of striker for:	kg:	
		32 mm ≤ $d_n$ ≤ 41 mm	1,25	
		50 mm ≤ $d_n$ ≤ 63 mm	2,0	
		75 mm ≤ $d_n$ ≤ 80 mm	2,5	
		90 mm ≤ $d_n$ ≤ 100 mm	3,2	
		$d_n$ = 110 mm	4,0	
		$d_n$ = 125 mm	5,0	
		$d_n$ = 160 mm	8,0	
$d_n$ = 200 mm	10,0			
$d_n$ ≥ 250 mm	12,5			

<sup>1)</sup> For PP-copolymer only.

## 8 Physical characteristics

### 8.1 Physical characteristics of pipes

When tested in accordance with the test methods as specified in Table 13 using the indicated parameters, the pipe shall have physical characteristics conforming to the requirements given in Table 13.

**Table 13: Physical characteristics of pipes**

Characteristic	Requirements	Test parameters		Test method
Longitudinal reversion	≤ 2 %  The pipe shall exhibit no bubbles or cracks	Test temperature	(150 ± 2) °C	EN 743:1994 Method A <sup>1)</sup> Liquid
		Immersion time	30 min	
		or		
		Test temperature	(150 ± 2) °C	EN 743:1994 Method B <sup>1)</sup> Air
		Immersion time	60 min	
Melt mass-flow rate (MFR-value)	Permitted max. deviation when processing the compound into a pipe: 0,2 g/10 min	Condition 12: Test temperature	230 °C	ISO 4440-1:1994 together with ISO 4440-2:1994
		Reference time	10 min	
		Loading mass	2,16 kg	

<sup>1)</sup> The choice of method A or method B is in the responsibility of the manufacturer.



## 8.2 Physical characteristics of fittings

When tested in accordance with the test methods as specified in Table 14 and Table 15 using the indicated parameters, the fittings shall have physical characteristics conforming to the requirements given in Table 14 or Table 15, as applicable.

**Table 14: Physical characteristics of fittings**

Characteristic	Requirements	Test parameters		Test method
Effects of heating	1) 2) 3)	Test temperature Heating time	(150 ± 2) °C 30 min	EN 763: 1994 Method A Air oven
<p><sup>1)</sup> The depth of cracks, delamination or blisters shall not be more than 20 % of the wall thickness around the injection point(s). No part of the weld line shall be open to a depth of more than 20 % of the wall thickness.</p> <p><sup>2)</sup> When fittings are manufactured from pipes, the pipes shall conform to the requirements given in Table 9 and Table 13.</p> <p><sup>3)</sup> Mouldings that are used for fabricated fittings may be tested separately.</p>				

**Table 15: Physical characteristics of fabricated fittings**

Characteristic	Requirement	Test parameters		Test method
Watertightness <sup>1)</sup>	No leakage	Water pressure Duration	0,5 bar <sup>2)</sup> 1 min	EN 1053
<p><sup>1)</sup> Only for fabricated fittings made from more than one piece. A sealing ring retaining mean is not considered as a piece.</p> <p><sup>2)</sup> 1 bar = 100 kPa</p>				

**9 Performance requirements**

When tested in accordance with the test methods as specified in Table 16 using the indicated parameters, the joints and the system shall have fitness for purpose characteristics conforming to the requirements given in Table 16.

**Table 16: Fitness for purpose characteristics of the system**

Characteristic	Requirements	Test parameters		Test method
Watertightness <sup>1)</sup>	No leakage	Shall conform to EN 1053		EN 1053
Airtightness <sup>1)</sup>	No leakage	Shall conform to EN 1054		EN 1054
Application area "B": Elevated temperature cycling	No leakage before and after the test; Sagging: DN ≤ 50: ≤ 3 mm DN > 50: 0,05d <sub>n</sub>	Shall conform to EN 1055		EN 1055:1996 Test assembly a) (Figure 1 and/or Figure 3)
Application area "BD": Elevated temperature cycling	No leakage before and after the test; Sagging: DN ≤ 50: ≤ 3 mm DN > 50: 0,05d <sub>n</sub>	Shall conform to EN 1055		EN 1055:1996 Test assembly b) (Figure 2)
Application area "BD": Tightness of elastomeric ring seal joints		Test temperature	(23 ± 5) °C	EN 1277:1996 Method 4 Condition B
		Spigot deflection	≥ 10 %	
		Socket deflection	≥ 5 %	
		Difference	≥ 5 %	
	No leakage	Water pressure	0,05 bar	
	No leakage ≤ -0,27 bar	Water pressure Air pressure	0,5 bar -0,3 bar	
		Test temperature	(23 ± 5) °C	EN 1277:1996 Method 4 Condition C
		Angular deflection	2°	
	No leakage	Water pressure	0,05 bar	
	No leakage	Water pressure	0,5 bar	
	≤ -0,27 bar	Water pressure Air pressure	0,5 bar -0,3 bar	
Application area "BD": Long-term performance of TPE seals	Sealing pressure: a) at 90 d ≥ 1,3 bar  b) using extrapolation to 100 yr ≥ 0,6 bar	Shall conform to prEN 1989		prEN 1989

<sup>1)</sup> Not required for butt fusion joints.

**10 Requirements for application area “BD”**

**10.1 General**

Pipes and fittings intended to be used for application area “BD” shall conform to the requirements for application area “B” and additionally to the requirements given in this clause.

If national regulations require for use buried in ground within the building structure greater nominal outside diameters than 75 mm, these dimensions shall be taken into account.

For butt fusion joints, only those pipes and fittings (marked with “BD”) shall be used which are suitable for use inside buildings and buried in ground within the building structure.

**10.2 Material characteristics**

The material for pipes and fittings used for application area “BD” shall conform to the requirements for resistance to internal pressure as specified in Table 17. The material shall be tested in the form of a pipe.

**Table 17: Material characteristics**

Characteristic	Requirement	Material type and test designation	Test parameters		Test method
Resistance to internal pressure	No failure during the test period	PP-H: Test at 140 h at 80 °C	End caps Test temperature Orientation Sampling sizes and series Number of test pieces Circumferential (hoop) stress Conditioning period Type of test Test period	Types a or b (80 ± 1) °C free prEN 1451-7 3 6,0 MPa 60 min Water-in-water ≥ 140 h	EN 921
		PP-H: Test at 1000 h at 95 °C	End caps Test temperature Orientation Sampling sizes and series Number of test pieces Circumferential (hoop) stress Conditioning period Type of test Test period	Types a or b (95 ± 1) °C free prEN 1451-7 3 3,5 MPa 60 min Water-in-water ≥ 1000 h	
		PP-copolymer: Test at 140 h at 80 °C	End caps Test temperature Orientation Sampling sizes and series Number of test pieces Circumferential (hoop) stress Conditioning period Type of test Test period	Types a or b (80 ± 1) °C free prEN 1451-7 3 4,2 MPa 60 min Water-in-water ≥ 140 h	
		PP-copolymer: Test at 1000 h at 95 °C	End caps Test temperature Orientation Sampling sizes and series Number of test pieces Circumferential (hoop) stress Conditioning period Type of test Test period	Types a or b (95 ± 1) °C free prEN 1451-7 3 2,5 MPa 60 min Water-in-water ≥ 1000 h	

**10.3 Mechanical characteristics**

Pipes used for application area "BD" shall conform to the requirements for ring stiffness as specified in Table 18.

**Table 18: Mechanical characteristics**

Characteristic	Requirement	Test parameters		Test method
Ring stiffness	$SN \geq 4 \text{ kN/m}^2$	Test temperature	$(23 \pm 2) \text{ }^\circ\text{C}$	EN ISO 9969
		Deflection Deflection speed for: 75 mm $\leq d_n \leq$ 110 mm 110 mm $< d_n \leq$ 200 mm 200 mm $< d_n \leq$ 315 mm	3 %  ( 2 $\pm$ 0,4) mm/min ( 5 $\pm$ 1,0) mm/min (10 $\pm$ 2,0) mm/min	

**11 Sealing rings**

**11.1** Various designs of sealing rings for ring seal sockets are permitted provided that the joints conform to the requirements as specified in clause 9.

Materials for sealing rings shall conform to EN 681-1 or prEN 681-2, as applicable.

**11.2** The sealing ring shall not have any detrimental effects on the properties of the pipe or fitting.

**11.3** Thermoplastics elastomer (TPE) seals for application area "BD" shall additionally conform to the long-term performance requirements as specified in clause 9.

**12 Marking**

**12.1 General**

**12.1.1** Marking elements shall be labelled, printed or formed directly on the component in such a way that after storage, weathering, handling and installation the required legibility is maintained.

One of the following two levels of legibility of the marking on the components are specified for the individual marking aspects given in Table 19 and Table 20. as applicable. The required durability of marking is coded as follows:

The symbols for the legibility mean the following:

- a: durable in use;
- b: legible until the system is installed.

**NOTE:** The manufacturer is not responsible for marking being illegible, due to actions caused during installation and use such as painting, scratching, covering of the components or by use of detergents etc. on the components unless agreed or specified by the manufacturer.

**12.1.2** Marking shall not initiate cracks or other types of defects which adversely influence the performance of the pipe or fitting.

**12.1.3** If printing is used, the colouring of the printed information shall differ from the basic colouring of the pipe or fitting.

**12.1.4** The size of the marking shall be such that the marking is legible without magnification.

**12.1.5** If pipes and fittings according to this standard are certified by an independent third party, they may be marked accordingly.

**12.2 Minimum required marking of pipes**

The minimum required marking of pipes shall conform to Table 19.

Pipes shall be marked at intervals of maximum 1 m, at least once per pipe. Pipes with a length less than 1 m may be marked with a label at least once per pipe.

**Table 19: Minimum required marking of pipes**

Aspects	Marking or symbol	Minimum durability of legibility of marking
– Number of the standard– Manufacturer's name and/or trade mark	EN 1451	a
– Nominal size– Minimum wall thickness	XXX e.g. DN 110	a
– Material <sup>1)</sup>	e.g. 3,4	a
– Application area code	PP or PP-H	a
– For application area "BD": Pipe series	"B" or "BD"	a
– MFR-class <sup>2)</sup>	e.g. S 16	a
– Cold climate performance <sup>3)</sup>	e.g. MFR-A ★ (ice crystal)	a b
– Manufacturer's information	4)	a

<sup>1)</sup> Pipes which are marked "PP" are made from PP-copolymer. Pipes made from PP-homopolymer shall be marked "PP-H".

<sup>2)</sup> For pipes intended for butt fusion.

<sup>3)</sup> This marking is only applicable to pipes which by testing have proved to conform to 7.2.

<sup>4)</sup> For providing traceability the following details shall be given:  
a) the production period (year and month) in figures or in code;  
b) a name or code for the production site if the manufacturer is producing at different sites.

### 12.3 Minimum required marking of fittings

The minimum required marking of fittings shall conform to Table 20, whereby the manufacturer's information can be either on the fitting or on the packaging. If the manufacturer's information is on the packaging it shall be determined by national requirements.

**Table 20: Minimum required marking of fittings**

Aspects	Marking or symbol	Minimum durability of legibility of marking
- Number of the standard	EN 1451	b
- Manufacturer's name and/or trade mark	XXX	a
- Nominal size	e.g. DN 110	a
- Nominal angle	e.g. 67,5 °	b
- Material <sup>1)</sup>	PP or PP-H	a
- Application area code	"B" or "BD"	a
- For application area "BD": Minimum wall thickness or pipe series	e.g. 3,4 or S 16	a
- MFR-class <sup>2)</sup>	MFR-A	a
- Manufacturer's information	<sup>3)</sup>	b

<sup>1)</sup> Fittings which are marked "PP" are made from PP-copolymer.  
Fittings made from PP-homopolymer shall be marked "PP-H".  
<sup>2)</sup> For fittings intended for butt fusion.  
<sup>3)</sup> For providing traceability the following details shall be given:  
a) the production period (year) in figures or in code;  
b) a name or code for the production site if the manufacturer is producing at different sites.

### 13 Installation of piping systems

For the installation of pipes and fittings conforming to this standard, national and/or local requirements and relevant codes of practice apply.

In addition the pipe manufacturer may give a recommended practice for installation which refers to transport, storage and handling of the pipes and fittings as well as to the installation in accordance with the applicable national and/or local instructions.

For external above ground application additional requirements depending on the climate shall be agreed between the manufacturer and the user.

Due to the limited impact strength at low temperatures pipes and fittings made from PP-homopolymer are not intended to be installed at temperatures below +5 °C.

## Annex A (informative)

### General characteristics of PP pipes and fittings

#### A.1 General

EN 476 specifies the general requirements for components used in discharge pipes, drains and sewers for gravity systems. Pipes and fittings conforming to this standard fully meet these requirements. Furthermore the following information is given.

#### A.2 Material characteristics

Pipes and fittings conforming to this standard have generally these characteristics:

– Modulus of elasticity	$E_{(1 \text{ min})} > 1\,200 \text{ MPa};$
– Average density	$\approx 0,9 \text{ g/cm}^3;$
– Average coefficient of linear thermal expansion	$\approx 0,14 \text{ mm/m}\cdot\text{K};$
– Thermal conductivity	$\approx 0,2 \text{ W/m}\cdot\text{K};$
– Specific heat capacity	$\approx 2000 \text{ J/kg}\cdot\text{K};$
– Surface resistance	$> 10^{13} \Omega.$

#### A.3 Ring stiffness

The ring stiffness of pipes conforming to this standard is determined in accordance with EN ISO 9969 and is as follows:

- $\geq 4 \text{ kN/m}^2$  for S 16;
- $\geq 6,3 \text{ kN/m}^2$  for S 14.

When a fitting conforming to this standard has the same wall thickness as the corresponding pipe, the stiffness of this fitting because of its geometry, is equal to or greater than the stiffness of that pipe.

The actual value of stiffness of the fittings can be determined in accordance with ISO/DIS 13967:1995.

#### A.4 Chemical resistance

PP piping systems conforming to this standard are resistant to corrosion by water with a wide range of pH-values such as soil and waste water, rain water, surface water and ground water.

If piping systems conforming to this standard are to be used for chemical contaminated waste water, such as industrial discharges, chemical and temperature resistance have to be taken into account.

For information about the chemical resistance of PP guidance is given in ISO/TR 10358:1993 and for rubber materials in ISO 7620:1986.

**Bibliography****EN 476**

General requirements for components used in discharge pipes, drains and sewers for gravity systems

**prEN 1329**

Plastics piping systems for soil and waste discharge (low and high temperature) within the building structure - Unplasticized poly(vinyl chloride) (PVC-U)

**EN 1401-1**

Plastics piping systems for non-pressure underground drainage and sewerage - Unplasticized poly(vinyl chloride) (PVC-U) - Part 1: Specifications for pipes, fittings and the system

**prEN 1451-6**

Plastics piping systems for soil and waste discharge (low and high temperature) within the building structure - Polypropylene (PP) - Part 6: Recommended practice for installation

**prEN 1453**

Plastics piping systems with structured-wall pipes for soil and waste discharge (low and high temperature) inside buildings - Unplasticized poly(vinyl chloride) (PVC-U)

**EN 1455**

Plastics piping systems for soil and waste discharge (low and high temperature) within the building structure - Acrylonitrile-butadiene-styrene (ABS)

**EN 1519**

Plastics piping systems for soil and waste discharge (low and high temperature) within the building structure - Polyethylene (PE)

**EN 1565**

Plastics piping systems for soil and waste discharge (low and high temperature) within the building structure - Styrene copolymer blends (SAN+PVC)

**EN 1566**

Plastics piping systems for soil and waste discharge (low and high temperature) within the building structure - Chlorinated poly(vinyl chloride) (PVC-C)

**EN 1852-1**

Plastics piping systems for non-pressure underground drainage and sewerage - Polypropylene (PP) - Part 1: Specifications for pipes, fittings and the system

**prEN 12056-1**

Gravity drainage systems inside buildings - Part 1: Scope, definitions, general and performance requirements

**prEN 12666-1**

Plastics piping systems for non-pressure underground drainage and sewerage - Polyethylene (PE) - Part 1: Specifications for pipes, fittings and the system

**ISO 7620:1986**

Rubber materials - Chemical resistance

**ISO/TR 10358:1993**

Plastics pipes and fittings - Combined chemical resistance classification table

**ISO/DIS 13967:1995**

Plastics piping systems - Thermoplastics fittings - Determination of the short-term stiffness

**RAL 840-HR<sup>1)</sup>**

Colour register

<sup>1)</sup> Obtainable at the national standard institutes.



---

## **BSI — British Standards Institution**

BSI is the independent national body responsible for preparing British Standards. It presents the UK view on standards in Europe and at the international level. It is incorporated by Royal Charter.

### **Revisions**

British Standards are updated by amendment or revision. Users of British Standards should make sure that they possess the latest amendments or editions.

It is the constant aim of BSI to improve the quality of our products and services. We would be grateful if anyone finding an inaccuracy or ambiguity while using this British Standard would inform the Secretary of the technical committee responsible, the identity of which can be found on the inside front cover. Tel: 020 8996 9000. Fax: 020 8996 7400.

BSI offers members an individual updating service called PLUS which ensures that subscribers automatically receive the latest editions of standards.

### **Buying standards**

Orders for all BSI, international and foreign standards publications should be addressed to Customer Services. Tel: 020 8996 9001. Fax: 020 8996 7001.

In response to orders for international standards, it is BSI policy to supply the BSI implementation of those that have been published as British Standards, unless otherwise requested.

### **Information on standards**

BSI provides a wide range of information on national, European and international standards through its Library and its Technical Help to Exporters Service. Various BSI electronic information services are also available which give details on all its products and services. Contact the Information Centre. Tel: 020 8996 7111. Fax: 020 8996 7048.

Subscribing members of BSI are kept up to date with standards developments and receive substantial discounts on the purchase price of standards. For details of these and other benefits contact Membership Administration. Tel: 020 8996 7002. Fax: 020 8996 7001.

### **Copyright**

Copyright subsists in all BSI publications. BSI also holds the copyright, in the UK, of the publications of the international standardization bodies. Except as permitted under the Copyright, Designs and Patents Act 1988 no extract may be reproduced, stored in a retrieval system or transmitted in any form or by any means – electronic, photocopying, recording or otherwise – without prior written permission from BSI.

This does not preclude the free use, in the course of implementing the standard, of necessary details such as symbols, and size, type or grade designations. If these details are to be used for any other purpose than implementation then the prior written permission of BSI must be obtained.

If permission is granted, the terms may include royalty payments or a licensing agreement. Details and advice can be obtained from the Copyright Manager. Tel: 020 8996 7070.

This document was created with Win2PDF available at <http://www.daneprairie.com>.  
The unregistered version of Win2PDF is for evaluation or non-commercial use only.